



SI 0103
For technical personnel only!
1/2

SERVICE INFORMATION

ELECTRIC RECIRCULATING AIR VALVES

TECHNOLOGY TO PREVENT TURBO LAG

The bypass valve prevents unnecessary braking of the turbocharger with sudden closing of the throttle valve, so clearly reducing the turbo lag effect.

Compared with existing pneumatic solutions the electric bypass valve is more compact, efficient and cost-effective: There is no need for pneumatic lines, a vacuum tank, non-return valve or electric air switching valve.

Direct actuation cuts switching times by as much as 70 percent, a particular benefit for sporty turbocharged engines with fast load alternation.



Bypass valve in VW EOS TFSI (highlighted in red)



All content including pictures and diagrams is subject to change. For assignment and replacement, refer to the current catalogues or systems based on TecAlliance.



SI 0103

For technical personnel only!

2/2

FUNCTION

If the accelerator is suddenly released at a high turbocharger speed (causing the throttle valve to close), a high back pressure is produced behind the compressor and is not able to escape. This has a strong braking effect on the compressor wheel, exposing the closed throttle valve and turbine side of the turbocharger to great loads.

When the throttle valve opens, the turbocharger first has to be brought back up to speed. This effect is known as turbo lag, i.e. a lack of power when accelerating after overrun operation.

The bypass valve will prevent this. It releases a bypass to the suction side in overrun, so ensuring a fast drop in pressure on the compressor side. This means that the braking effect on the compressor is not as strong. When the driver accelerates again, i.e. when the throttle valve opens, the recirculating air valve closes, and full boost pressure is immediately available again. This reduces turbo lag, which is now barely noticeable.

Pierburg has incorporated the electrically operated recirculating air valve into the turbocharger design, creating a highly complex component for new engine generations.

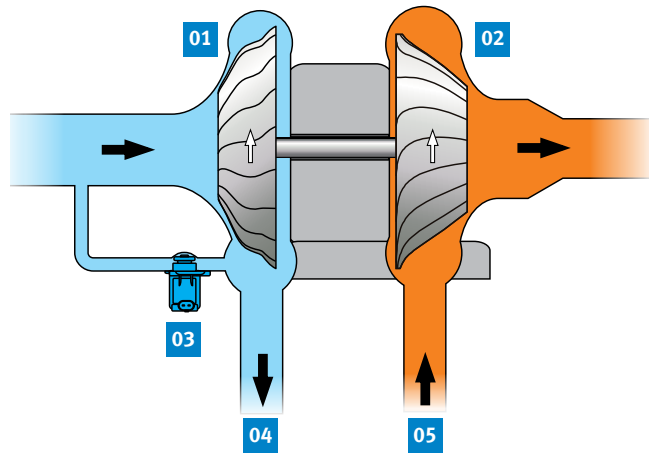

Functioning of a bypass valve:

- 01 Compressor
- 02 Turbine
- 03 Bypass valve
- 04 To throttle valve
- 05 From cylinders

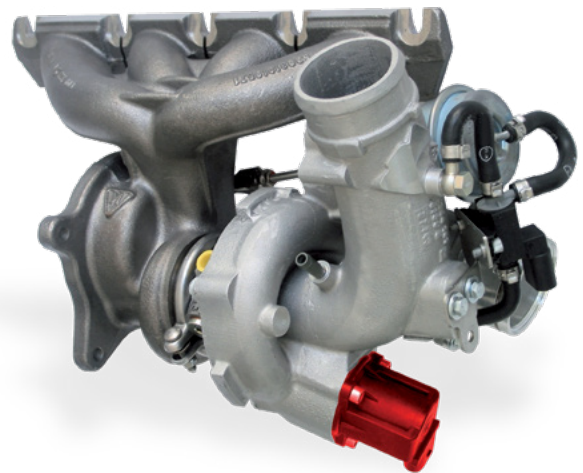

Bypass valve (highlighted in red) on the turbocharger of an Audi A3 2.0 TFSI